

2019-01.26 Burns Night Tamburin Stuttgart

1 WELCOME TO AYR J32 · 3/4L

Jill Hendricksen/Kathy Stewart: RSCDS XLVII 8 · Crib: E-cribs · Diagram: Keith Rose's Diagrams

- 1- 1c+2c DbIFig8, 1c crossing down to start, at end 2c face out
- 9- 1c+2c turn EH 1¼ on side (2c to 1pl) and 1c face down NHJ ; 1c dance down and turn 3c EH, 3c finish in 3pl and 1c facing 1cnr
- 17- 1c+1cnrs ½ diag. Reel4 and pass Rsh ; repeat with 2cnrs, 1c finish on midline Lsh to Lsh facing own side
- 25- 3c+1M & 1W+2c RHA (3x,1x,2x) ; All chase clw ½ round (2,1,3)

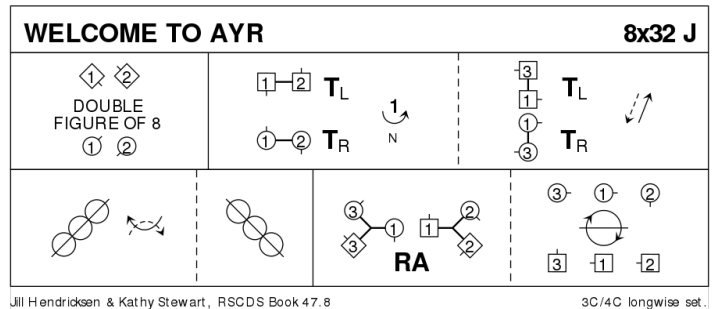

2 THE WHITE COCKADE R32 · 3/4L

Preston (18C): RSCDS V 11 · Crib: E-cribs · Diagram: Keith Rose's Diagrams

- 1- 1c+2c+3c set and cross RH ; repeat
- 9- 1c lead down the middle ; and up, staying in the middle
- 17- 1c long cast to 2pl (2c up) ; 1c+3c circle4 L
- 25- 2c+1c R&L.

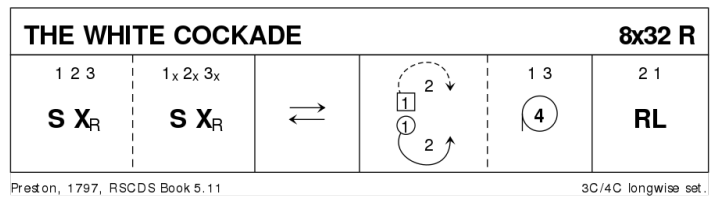

3 IT WISNAE ME S32 · 4/4L

Marjorie Macrae: RSCDS XLVII 10 · Crib: E-cribs · Diagram: Keith Rose's Diagrams

3c+4c cross on second chord (1,2,3x,4x)

- 1- 1c+4c cross RH, cast (2c+3c step to end) ; ½ Fig8 round end cpl (2,1,4x,3x)
- 9- Modified Half Grand Chain: 2c & 3c turn P RH 1½ **while** on sideline 1c+4c turn RH 1½ {3}, all turn next dancer LH ½ {1} (4x,2x,3,1) ; repeat (3,4,1x,2x)
- 17- Reels4 on the sidelines (3,4,1x,2x)
- 25- 3c+2c chase ½ clw **while**{4} 4c+1c LHA ; 2c+4c & 1c+3c RHA (2,4,1x,3x)

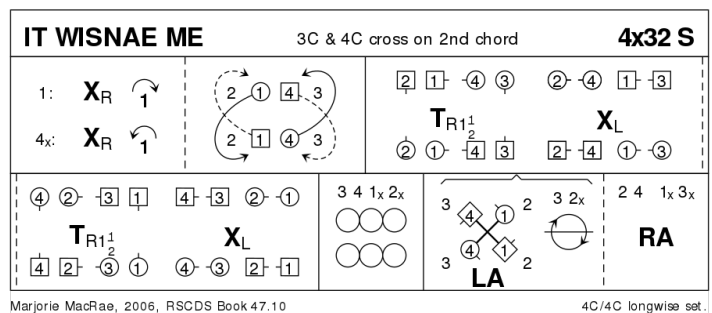

4 OH, WHISTLE AND I'LL COME TAE YE, MY LAD

J32 · 3/4L

RSCDS XXIV 6 · Crib: E-cribs · Diagram: Keith Rose's Diagrams

- 1- 1c+3c cross RH into Mirror Reels3 on opposite sides (2c in and up)
- 9- 1c+3c cross back RH and repeat the reels
- 17- 1c cast off, meet below 3c ; lead to top and cast off to 2pl (2c up)
- 25- 2c+1c+3c set, cross RH ; repeat.

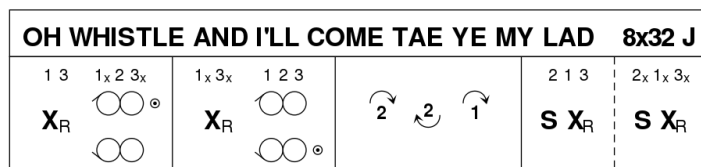

RSCDS Book 24.6

3C/4C longwise set.

5 BRATACH BANA R32 · 3/4L

John Drewry: Bon Accord Book of Scottish Country Dances · Crib: E-cribs · Diagram: Keith Rose's Diagrams

- 1- 1c turn RH | cast off (2c up) ; ½ Fig8 to R around 1cnr (to 2,1x,3)
- 9- ½ Reel3 on sides (Rsh to 2cnr) ; ½ Reel3 across (Lsh to 3cnr position), finish on sides (3x,1,2x)
- 17- 1c turn ¾ LH, Turn 1cnr person (3cnr position) RH ; pass Rsh, turn 2cnr person (4cnr position) ¾ RH to promhold (cnr on the right)
- 25- These pairs change places Rsh | drop left hand and turn RH ½ to sidelines ; half diagonal R&L (1st diagonal direction)

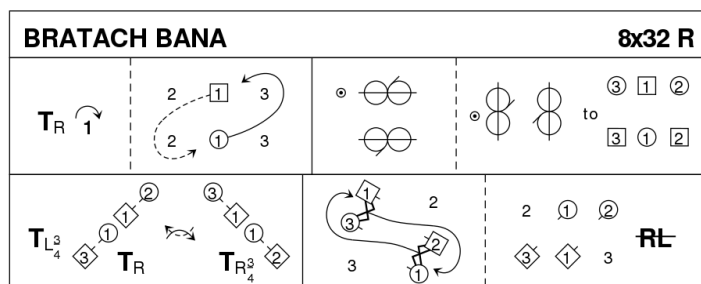

John Drewry, Bon Accord Book

3C/4C longwise set.

Note on [27-28]: originally 2 PdB. modified by Drewry to SkCh. O. Otto says best variant is corners in PdB, 1c in SkCh

6 MEMORIES OF MARY ANN S32 · 3/3L

Pam Stephens: RSCDS XLVII 7 · Crib: E-cribs · Diagram: Keith Rose's Diagrams

- 1- 1c set | cast off (2c up) ; ½ Reels3 across Lsh to 1cnr (2x,1x,3x)
- 9- S&Link3 to lines across ; 1c turn LH to face 1cnr (pos.)
- 17- 1c+1cnrs ½ Reel4 , pass Rsh ; repeat with 2cnr, 1c crossing Rsh to (2,1,3)
- 25- 3c+1c The Knot (2,3,1)

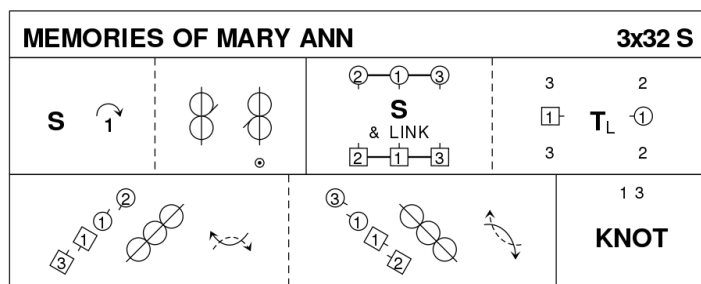

Pam Stephens, RSCDS Book 47.7

3C/3C longwise set.

7 THE STARRY EYED LASSIE J32 · 3/4L

Martin Sprague: RSCDS XXIII 11 · Crib: E-cribs · Diagram: Keith Rose's Diagrams

- 1- 1c+2c RHA ; 1c cast off **while{2}** 2c dance to top | 1c set advancing swiveling R to finish BtoB facing own sides for
- 9- DTr, finish with a petronella to between end couples facing 4cnr
- 17- Rsh Reels3 across (to 2,1x,3)
- 25- 2c+1c+3c circle6 L {6} | 1c cross RH

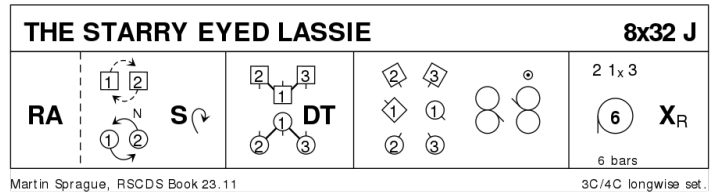

8 THE DEIL AMANG THE TAILORS R32 · 3/4L

RSCDS XIV 7 · Crib: E-cribs · Diagram: Keith Rose's Diagrams

- 1- 1c+2c set, ½ RHA ; set, ½ LHA
- 9- 1c lead down the middle and up, 2c step in for
- 17- 1c+2c Allemande
- 25- 2c+1c+3c circle6 and back.

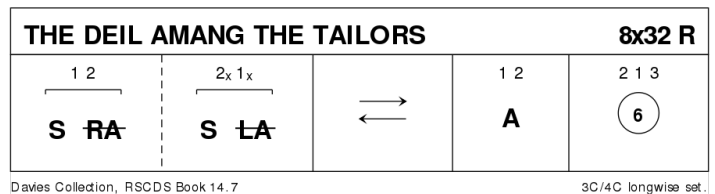

9 THE THREE SISTERS S32 · 3/4L

John Drewry: Scottish Country Dances in Diagrams. Ed. 8 · Crib: E-cribs · Diagram: SCDDDB Contributed Cribs & Diagrams

- 1- 1c+2c+3c all W A&R and set **while{6}** all M set, A&R | all cross RH
- 9- All C set, Petronella to midline ; turn BH, Petronella back to (1,2,3), 1W+2M face out
- 17- 1c+2c Reel4 across, 1M+2W starting Lsh, and 1W+2M cast R, at end 1W+2M turn LH into:
- 25- 1c+2c Rondel.

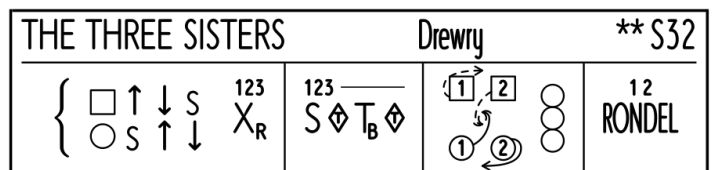

10 ROARING JELLY J32 · 3/4L

Hugh Foss: Glendarroch Scottish Dance Sheets · Crib: E-cribs · Diagram: Keith Rose's Diagrams

- 1- 1c cross RH | cast off (2c up) ; cross RH, 1c casts R round 3cnr to finish in line across between 2cnr and 3cnr
- 9- Circle6 and back
- 17- 1c change places up/dn RH | Fig8 round 4cnr and 1cnr, start Rsh), finish on sideline facing 2cnr
- 25- 1c Reels3{6} on opposite sides (Rsh to 2cnr) | cross RH

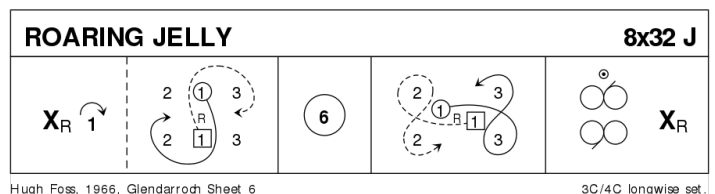

11 THE BARMKIN R88 · 4S

Roy Goldring: A Second Book of Graded Scottish Country Dances · Crib: E-cribs · Diagram: Keith Rose's Diagrams

- 1- 1c+3c turn RH and face clw ; chase ½ round set into
- 9- 3c+1c RHA ; LHA to exchanged places (3,2,1,4)
- 17-32 2c+4c repeat [1-16] (3,4,1,2)
- 33- 1c+3c turn LH and face cclw ; chase ½ round set to own places
- 41- 1c+3c R&L (1,4,3,2)
- 49-64 2c+4c repeat [33-48] (1,2,3,4)
- 65- All C NHJ advance | retire »diagonally« NHJ with cnr ; all W dance clw round their cnr
- 73- All pairs advance | retire NHJ with P to places ; all M dance clw round P
- 81- All circle8 and back

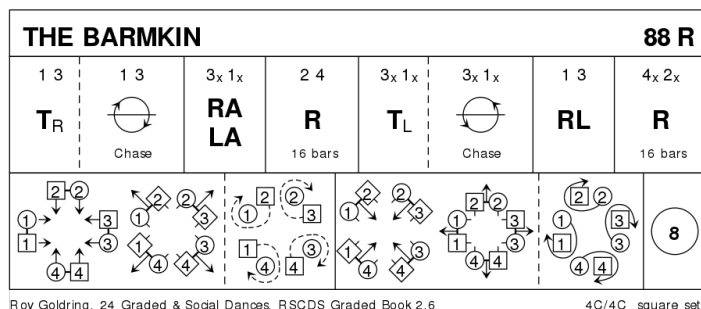

12 DONALD BANE S32 · 3/4L

Thomas (19C) Wilson: RSCDS XVII 12 · Crib: E-cribs · Diagram: Keith Rose's Diagrams

- 1- Mirror reels on own sides, 1c starting in and down
- 9- 1c+2c RHA {3} 1c cast as 2c dance up ; 1c+3c LHA (2,1,3)
- 17- All circle6 and back, 1c finish facing corners
- 25- 1c set to 1cnr, to P, to 2cnr, petronella to 2pl

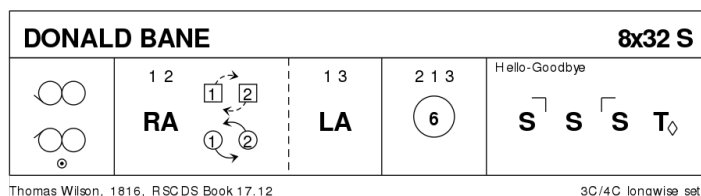

13 'I'LL MAK' YE FAIN TO FOLLOW ME J32 · 3/4L

W Boag (18C): RSCDS VI 10 · Crib: E-cribs · Diagram: Keith Rose's Diagrams

- 1- 1W casts off 2, 1M following, to 3pl opposite sides (2c+3c up) ; 1M casts up 2, 1W following, to own places (2c+3c down)
- 9- 1c cross RH, cast off one (2c up) ; cross LH, cast off one and lead up to 1cnrs
- 17- 1c set to and turn corners
- 25- Reels3{6} on the sides | 1c cross (2,1,3).

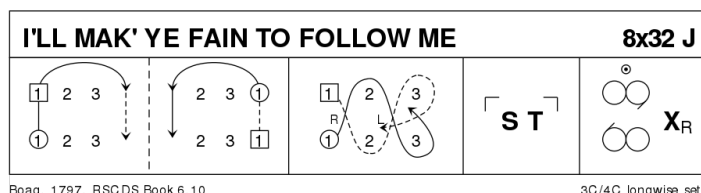

14 THE BLACK MOUNTAIN REEL R32 · 5/5L

Derek Haynes: Carnforth Collection of SC Dances 3 · Crib: E-cribs · Diagram: Keith Rose's Diagrams

- 1- 1c & 3c cross RH | cast off (2c+4c up) ;
½ Fig8 up and face 1cnr
- 9- Turn CPCP (1c & 3c turn 1cnr RH, P
LH, 2cnr RH, P LH), finish facing 1cnr
- 17- 1c & 3c Reels4 with 1cnrs, at the end
pass P Lsh.
- 25- 1W+2c (top), 1M+4c+3W (middle) and 3M+5c (bottom) RHA ; 1c & 3c turn LH and cast off
(4c+5c up). (to: 2,4,1,5,3)

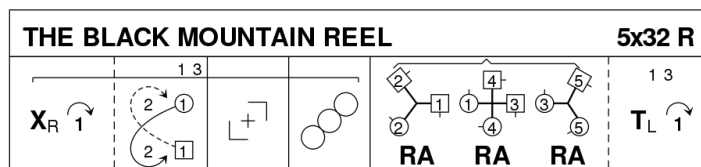

Derek Haynes, 1968, Carnforth Collection 3

5C/5C longwise set.

15 CHERRYBANK GARDENS S32 · 3/3L

John Drewry: Bankhead Book Part 1 · Crib: E-cribs · Diagram: Keith Rose's Diagrams

- 1- 1c+2c set | petronella in tandem ;
repeat (2x,1x,3)
- 9- 2c+1c set | 2c cross RH while{2} 1c
cross LH ; 1W+2c & 1M+3c RHA
(Teapots) to sidelines (2,1,3)
- 17- 1c+3c S&Link ; 3c+1c circle4 left, end
3c facing 1c for
- 25- G-Chain (2c cross to start) (2, 3, 1)

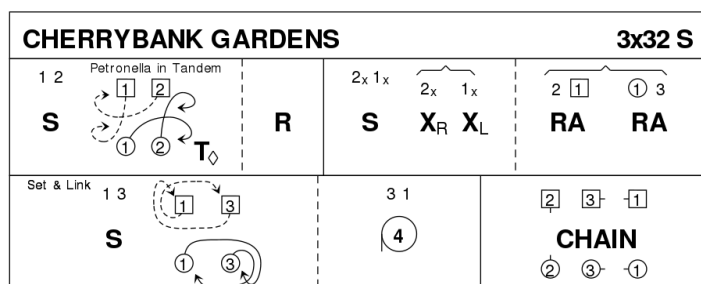

John Drewry, 1991, Bankhead 1

3C/3C longwise set.

16 KENDALL'S HORNPIPE J32 · 2/4L

RSCDS Graded 22 · Crib: E-cribs · Diagram: Keith Rose's Diagrams

- 1- 1c+2c R&L
- 9- 1c Lead down the middle {3} and up
{3}, cross and cast off (2c up) (to 2, 1x)
- 17- 2c+1c L-Chain (2,1x)
- 25- 1c+2c A&R ; 1c turn RH 1½ (2,1)

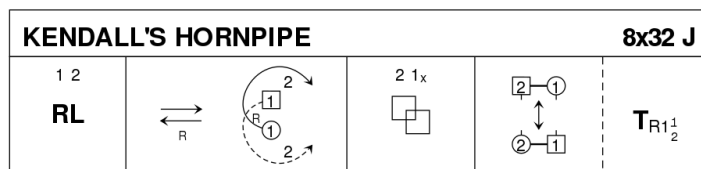

RSCDS Graded Book 1.22

2C/4C longwise set.

17 CAMPBELL'S FROLIC J32 · 3/4L

David Rutherford: RSCDS XV 3 · Crib: E-cribs · Diagram: Keith Rose's Diagrams

- 1- 1c+2c set | RHA | 1c cast off and 2c
dance to top (2,1,3)
- 9- 1c+3c set | LHA | 1c cast to 3pl and 3c
dance up (2,3,1)
- 17- 1c set | lead to top (3c down) | cast to
2pl
- 25- 2c+1c+3c circle6 and back

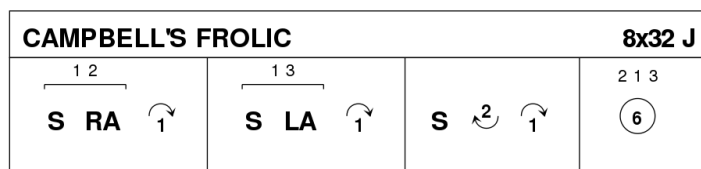

Rutherford, 1750, RSCDS Book 15.3

3C/4C longwise set.